



ELSEVIER

15 August 1999

OPTICS  
COMMUNICATIONS

Optics Communications 167 (1999) 273–282

www.elsevier.com/locate/optcom

Full length article

# Injection locking suppression of coherence collapse in a diode laser with optical feedback

J.S. Lawrence<sup>\*</sup>, D.M. Kane<sup>1</sup>

*Physics Department, Macquarie University, Sydney, NSW 2109, Australia*

Received 12 April 1999; received in revised form 10 June 1999; accepted 15 June 1999

## Abstract

The effects of injection locking a laser diode which is also subject to varying levels of optical feedback from an external reflector are investigated. It is found that the locking range of a laser diode with optical feedback (LDWOF) is reduced relative to that of a solitary laser diode depending on both the increased photon lifetime and the amount of optical feedback. When the LDWOF is locked in frequency to the external injection source then the coherence collapse, and other low optical feedback regimes of operation, are suppressed. This result can be applied to produce a self-locked or master/slave-locked diode laser system that is insensitive to unwanted feedback typically encountered in practical communication systems. The effect of injection locking a frequency modulated external cavity diode laser (FM ECDL) system by another laser is to inhibit the modulation induced coherence collapse that is characteristic of such FM systems. Due to this, larger bandwidths are attainable than for free running FM ECDLs. This also suggests future device and system designs for obtaining very broad optical bandwidth FM operation. © 1999 Published by Elsevier Science B.V. All rights reserved.

## 1. Introduction

Semiconductor diode lasers with optical feedback have been studied extensively for almost twenty years [1–3]. Optical feedback can induce detrimental or advantageous effects, dependent on the level of the feedback. Advantageous effects, such as reduced laser linewidth, reduced operating threshold, and increased side mode suppression, occur for very low or strong feedback (regimes I, III, and V) [4]. However,

at low to intermediate feedback levels (regime IV) the device operates in a coherence collapsed state, which is characterised by dynamic instabilities, and a dramatically broadened optical frequency spectrum. In a real optical system there will always be unwanted feedback, arising from, for example, fibre-optic end faces, couplers, or optical discs, which may cause such collapse of the coherence of the laser systems' output. Various schemes have been proposed to combat this transition to chaos [5,6]. These include using expensive optical isolators, or very high quality anti-reflection coatings on all surfaces, and careful control of diode design parameters. Also, there are various methods of chaos control, such as high frequency injection [7,8] or dynamic targeting [9], that force a system operating in a

<sup>\*</sup> Corresponding author. Tel.: +61-2-9850-7901; fax: +61-2-9850-8115; e-mail: jl@ics.mq.edu.au

<sup>1</sup> E-mail: debkane@physics.mq.edu.au

chaotic state to operate in a more stable state—typically one with power which is time varying. In this study it is shown that strong optical injection from an external source overrides coherence collapse in a laser diode just as strong self injection is observed to prevent coherence collapse in an external cavity laser system. These ideas are then generalised to proposals for integrated laser diode designs which will be insensitive to optical feedback up to levels well above those that normally cause coherence collapse.

Injection locking of a solitary semiconductor laser by another single frequency source has been reported in numerous papers [10–14]. Similar to optical feedback, such optical injection has various effects: it may induce dynamic instabilities [15], or if the frequency detuning is small enough it may lock the two lasers in frequency, providing noise suppression and linewidth narrowing [8].

Some research has been reported on the transient dynamics and spectral and spatial characteristics of a semiconductor laser which is subject to both optical injection from another laser, and optical or optoelectronic feedback [16–18]. The study reported here examines the effects of optical injection on a LDWOF from an external reflector, particularly with respect to the optical frequency spectrum of the LDWOF before the external injection locking source is introduced. It is found that injection locking an LDWOF system which is operating in a coherence collapsed state can force the system to operate on a stable single longitudinal mode. This shows the potential for significant application in device design for insensitivity to optical feedback.

An FM ECDL is produced by directly modulating the injection current of the ECDL, or by intra-cavity phase modulation [19,20]. If the modulation frequency is very close to the longitudinal mode spacing of the laser (which is determined by the total length including the external cavity) then the system should operate as a mode locked laser [21]. If the modulation frequency is detuned by a small amount from the cavity mode spacing then the FM laser output is characterised by a power which is constant in time but whose optical frequency spectrum consists of a comb of modes separated by the modulation frequency, and where the amplitude of each mode is given by a Bessel function [22–24]. Previous work, on long cavity FM ECDLs, showed that at

any particular detuning of the modulation frequency from the longitudinal mode spacing of the external cavity, there is a maximum useable modulation power above which there is a transition to a dynamically unstable state, similar to that found in regime IV (coherence collapse) [19,20]. This maximum modulation power implies that the system has a maximum modulation bandwidth, which is a disadvantage for many applications requiring large bandwidths, such as frequency division multiplexing and spectroscopy. The value of this maximum bandwidth is dependent upon a number of factors, such as the detuning of the longitudinal mode spacing of the external cavity from the modulation frequency, the modulation power, and the effective reflectivity of the external reflector. We have studied the influence of injection locking on such modulation characteristics, and have found that larger bandwidths are possible in the injection locked FM ECDL, than in the free running FM ECDL by virtue of suppression of the modulation induced coherence collapse in the injection locked FM ECDL.

## 2. Theory

The locking range,  $\Delta f_{\text{IL}}$ , for a diode laser subjected to injection from another diode laser has been derived as the steady state solution of the rate equations for injection locking, and is given by [10,12]

$$\frac{c\sqrt{1+\alpha^2}}{4\pi nL} \sqrt{\frac{P_{\text{in}}}{P_1}} \geq \Delta f_{\text{IL}} \geq \frac{c}{4\pi nL} \sqrt{\frac{P_{\text{in}}}{P_1}}, \quad (1)$$

where  $P_1$  and  $P_{\text{in}}$  are the injection locked output power and the injected power, respectively (i.e.  $P_{\text{in}} \propto E_{\text{in}}^2$ ,  $P_1 \propto E_1^2$ ),  $n$  is the group index,  $c$  is the speed of light in vacuum,  $\alpha$  is the linewidth enhancement factor and  $L$  is the diode laser length. Reasonable agreement between this value and experimental data has previously been produced [12,25,26]. This model needs to be modified to describe the injection locking of a LDWOF. Simply setting  $L$  as the external cavity length in the equation above has the expected effect, i.e. the locking range is greatly reduced due to the increased round trip time in the external cavity, but the behaviour with changing levels of optical feedback is not predicted.

The phase rate equation for a diode laser with feedback and injected fields may be written as [2,25]

$$\begin{aligned} \frac{d\phi_1}{dt} = & -(\omega_1 - \Omega_0) \\ & + \frac{1}{2\tau_p} \frac{E_{in}}{E_1} \sin[(\omega_{in} - \omega_1)t + (\phi_{in} - \phi_1)] \\ & + \frac{\alpha}{2} \left( g - \frac{1}{2\tau_p} \right) E_1^2 \\ & - \frac{k_c}{\tau_p} \frac{E(t-\tau)}{E(t)} \sin[\omega_0\tau + \phi_1 - \phi(t-\tau)], \end{aligned} \quad (2)$$

where  $\omega_1$ ,  $\omega_0$ , and  $\omega_{in}$  are the output locked, the initial diode laser free running, and the injected signal angular frequencies, respectively. Other parameters are:  $\Omega_0$  the centre angular frequency of the resonator,  $g$  the diode gain,  $\tau$  the external round trip delay time, and  $k_c$  the coupling between the diode and the external cavity. For the case of weak optical feedback

$$k_c = \frac{1 - R_2}{\sqrt{R_2}} \sqrt{kR_{ext}}, \quad (3)$$

where  $R_{ext}$  is the reflectivity of the external mirror,  $R_2$  is the reflectance of the diode laser output facet,  $k$  is the coupling efficiency between the external reflector and the diode laser and  $\tau_p$  is the effective photon lifetime which is given by

$$\tau_p = \left\{ \frac{c}{n} \left( \alpha_i + \frac{1}{2L} \ln \left( \frac{1}{R_2} \right) \right) \right\}^{-1}, \quad (4)$$

where  $\alpha_i$  is the internal loss factor of the diode laser.

Nonlinear gain saturation and the dependence of the gain on the carrier density have been neglected in Eq. (2) for simplicity, and because the gain/loss terms (third component) are negligible compared with the feedback and injection terms in the steady state. Eq. (2) can thus be solved to obtain the locking range,  $2(\omega_1 - \Omega_0)/2\pi$ , as

$$\Delta f_{IL} = \frac{1}{2\pi\tau_p} \left[ \left( \sqrt{\frac{P_{in}}{P_1}} \right) - \left( 2k_c \sqrt{\frac{P_O}{P_1}} \right) \right], \quad (5)$$

with  $P_O$  being the optical feedback power. In experimental studies the physical parameters  $R_2$ ,  $k_c$ ,

$P_{in}/P_1$  and  $P_O/P_1$  are known imprecisely. Thus, it is appropriate to note that Eq. (5) can be modified to the form of

$$\Delta f_{IL} = \frac{1}{2\pi\tau_p} \left[ \sqrt{k_{in} \frac{P_{in}}{P_1}} - \sqrt{k_o \frac{P_O}{P_1}} \right] = \rho, \quad (6)$$

where  $k_{in}$  and  $k_o$  are coupling coefficients for the injected light and the optical feedback light, respectively. Expressing Eq. (6) in this form also overcomes the difficulty that the form of the coupling coefficient (Eq. (3)) for strong optical feedback is not available in an analytic form. The relationship between frequency locking range, injected power and optical feedback is thus determined by two competing terms; the first representing the injected field and the second the optical feedback field. If the injection term dominates the optical feedback term, then the locking range is positive and locking of the LDWOF to the injected laser is possible. If, however, the optical feedback term is dominant, then locking to the external injection source is not possible as the locking range is negative. The system may be interpreted, in this case, as being self-locked. This is unlike the case for injection locking a free-running diode laser without any optical feedback, where at any particular injection ratio ( $P_{in}/P_1$ ), there is always a detuning between the master and slave that will produce a frequency locked output state. If optical feedback is present at any particular level there is a minimum injection power below which injection locking is not possible, independent of the detuning. This is illustrated in Fig. 1, which shows

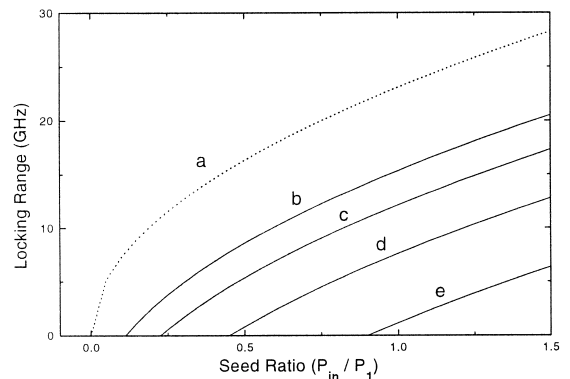

Fig. 1. Injection locking range versus injection power ratio for a number of different values of the optical feedback power ratio: (a) no feedback; (b) 0.05; (c) 0.1; (d) 0.2; and (e) 0.4.

the frequency locking range as a function of injection ratio ( $P_{in}/P_1$ ) for a number of different optical feedback levels ( $P_O/P_1$ ). By analogy with the analysis of Petitbon et al. [12], retention of the gain terms in Eq. (2) and its solution along with that for the photon density is expected to give an upper and lower bound on the injection locking bandwidth where Eq. (6) defines the lower bound. The injection locking bandwidth then lies in the range:

$$\sqrt{1 + \alpha^2} \rho \geq \Delta f_{IL} \geq \rho, \quad (7)$$

where  $\rho$  is defined by Eq. (6).

### 3. Experimental

The experimental set-up is shown in Fig. 2. The external cavity diode laser comprises an index guided quantum well GaAlAs diode (STC #LT50-03U, 850 nm, 50 mW cw), a collimating lens (Melles Griot #06LGT214 GRIN rod lens), and an external reflector which is one of 95, 90, 85 or 60% reflectance, placed 0.3 m from the diode laser and which also acts as the output coupler. A variable beam splitter is used inside the cavity to inject the external master laser. The injection source is a commercial tunable diode laser (New Focus #6126). The diagnostics are a power meter (Ophir Nova Display), a 10 or 1000 GHz FSR Fabry–Perot interferometer, a fast photodiode connected to a radio frequency spectrum analyser (Textronix #2754P), and a Burleigh wavemeter (#WA-10), or monochromator (SPEX #1870). Frequency modulation is achieved by applying an rf signal to the dc bias of the diode injection current

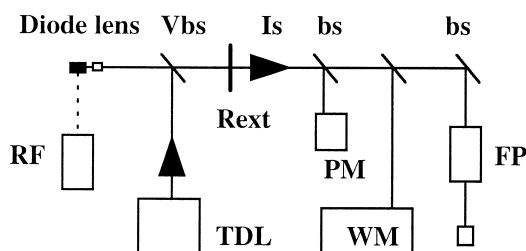

Fig. 2. Experimental apparatus. Vbs: variable beam splitter, bs: beam splitter, Is: optical isolator, FP: Fabry–Perot interferometer, PD: photodiode, WM: wavemeter or monochromator, PM: power meter, TDL: tunable diode laser,  $R_{ext}$ : external reflector, and RF: radio frequency signal generator (used only in part B).

(with a Marconi Instruments #2022C signal generator and bias Tee), or by intra-cavity phase modulation (with a Brewster cut LiNbO<sub>3</sub> crystal coupled to an inductor chosen to make the combined circuit resonant close to the cavity longitudinal mode spacing).

The injected signal is aligned by maximising the injection locked power outside the cavity. The injected signal power is typically several milliwatts, which is comparable with the ECDL intra-cavity power. The exact power of the injected signal fed into the LDWOF is difficult to measure. An upper limit on the coupling efficiency between the injected laser field and the diode laser is obtained by assuming, due to differences in the spatial modes between the two diode lasers, that it is less than the coupling efficiency between the optical feedback field and the diode. The coupling coefficient for optical feedback has been predicted as  $0.23 \pm 0.08$  from fits to slope efficiency and threshold current measurements as described in Refs. [27,28]. A lower limit is obtained by observing the power from the injected laser that is reflected off the diode laser's output facet, with no injected current into the diode. It is thus estimated that between 5% and 23% of the injected signal is coupled into the diode laser.

### 4. Results and discussion

#### 4.1. Injection locking of a free-running LDWOF

The effects of injection locking on the LDWOF are considered, dependent on the spectral and dynamic properties of the master and slave laser systems. The experiment involves injecting a single mode tunable diode laser beam into the cavity of the slave LDWOF and tuning the master frequency until injection locking occurs. When the slave LDWOF is operating on a stable single mode then injection locking with a stable single mode from the master laser produces single frequency output which is locked in frequency to the master and is larger in power, but not substantially different in terms of linewidth or side mode suppression, than the original slave laser system output. When the slave LDWOF is originally in a chaotic state, such as induced by external mirror misalignment, or by intra-cavity at-

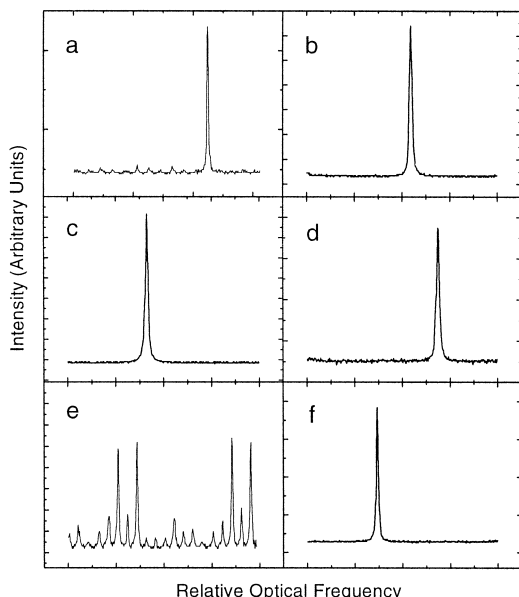

Fig. 3. Optical frequency spectra for (a) laser diode; (b) injection locked laser diode; (c) LDWOF (regime III); (d) injection locked LDWOF (regime III); (e) LDWOF (regime IV); and (f) injection locked LDWOF (regime IV). All spectra show approximately one free spectral range of the Fabry–Perot interferometer (1000 GHz). Injection current in each case is approximately  $1.2 I_{th}$  for the laser diode.

tenuation, then injecting a single mode signal of sufficient power and detuning to lock the two lasers (as given by Eq. (5)) causes the slave to oscillate in a single longitudinal mode with similar side mode suppression to the free-running regime V LDWOF (operating in a stable regime). This is found to be the case at any point in the chaotic regime IV. Thus, the output of the system is stable single mode regardless of the initial state of the LDWOF, and hence independent of the optical feedback level, provided that the external injection laser power is sufficiently large. This behaviour is displayed in Fig. 3. The output optical frequency spectrum for the diode laser with no feedback is shown in Fig. 3(a). The linewidth and side mode amplitudes are significantly reduced (below the instrumental sensitivity) when the laser diode is injection locked (Fig. 3(b)), or operated with feedback in regime III (Fig. 3(c)), or V. When the regime III laser is injection locked (Fig. 3(d)) the side mode suppression is not observed to change (i.e. the side mode suppression exceeds 30 dB). If the

laser diode is operated with feedback appropriate to produce coherence collapsed output (Fig. 3(e)), and then injection locked, the result is a stable single mode with side mode suppression again greater than 30 dB.

The range of frequencies of the master laser that allow injection locking as a function of the injection laser power ratio (note this is not the actual injection power ratio as it does not include the coupling coefficient) and the optical feedback level from the external cavity mirror has also been examined. The single mode master signal is injected into the slave LDWOF, and the master frequency tuned while observing the output optical frequency spectrum with a Fabry–Perot interferometer, at various FSR. Fig. 4(a) shows the experimental locking range as a function of feedback from the external mirror, for a number of different seed ratios. The locking range for a fixed seed power is found to rapidly decrease from that of the laser diode without optical feedback, as the level of optical feedback is increased. As expected, for any particular optical feedback level there is a particular injection power ratio below

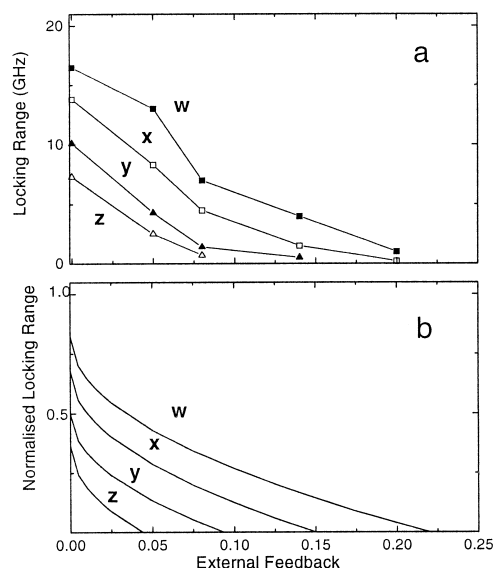

Fig. 4. (a) Experimental frequency locking range as a function of optical feedback power ratio ( $P_O/P_1$ ) for four injected power ratios:  $P_{in}/P_1 = 0.66$  (w),  $0.45$  (x),  $0.33$  (y), and  $0.15$  (z); and (b) normalised calculated locking range predicted using Eq. (6) with  $k_0 = 3k_{in}$ .

which the LDWOF will not lock to the injected signal.

The curves predicted from the theory (Eq. (6)) are shown in Fig. 4(b). Normalised quantities have been used for the frequency locking bandwidth in order to concentrate on the relative decrease in the injection locking bandwidth with increasing levels of optical feedback. It is the relative values of the coupling coefficients,  $k_{in}$  and  $k_O$ , that determines this rate of decline. The curves in Fig. 4(b) have a  $k_O$  value which is three times the  $k_{in}$  value. The magnitude of the injection locking bandwidth increases as the coupling coefficients increase and also depends on other laser diode parameters as shown in Eqs. (5) and (7). Using the lower limit of the injection locking bandwidth given in Eq. (7), and  $\tau_p$  of  $1.5 \pm 0.2$  ps [27] ( $R_2 = 0.04$ ,  $L = 350 \mu\text{m}$  and  $\alpha_i = 3400 \text{ m}^{-1}$  in Eq. (4)) the maximum locking bandwidths with no optical feedback require a  $k_{in}$  value of 0.037 to predict the experimentally observed values. This is a sensible value and is possibly high compared to injection coupling coefficients estimated in other studies. Using the upper limit of Eq. (7) will further reduce the injection coupling coefficient required to give agreement between the experimental and predicted injection locking bandwidth. With a  $k_{in}$  of 0.037 a value of  $k_O = 0.11$  is then required to give both quantita-

tative and qualitative agreement for the injection locking bandwidth as a function of both injection power ratio and optical feedback power ratio.

If the injection power ratio is not sufficient to lock the LDWOF to the injected signal, then there are two possible outcomes. If the seed power is slightly less, or the detuning slightly greater, than that necessary for locking (i.e. the terms in Eq. (6) are comparable) the effect of the seed is to force the master into a dynamically unstable state. This occurs regardless of the initial state of the LDWOF. For very low seed power compared with slave laser free running power, there is no apparent effect on the output spectrum, even when the seed is multimode. If a coherence collapsed seed beam (achieved through applying feedback into the master laser) is injected into a single mode (regime III or V) LDWOF, then below a certain seed ratio, the injected coherence collapsed signal has no effect and the output remains single mode.

The implications of these results are that they suggest a method exists of providing a semiconductor laser source that is insensitive to external reflection and does not require optical isolation. Three possible examples of such a system are shown in Fig. 5. Fig. 5(a) is simply a regime V LDWOF, where the output is taken from the opposite facet

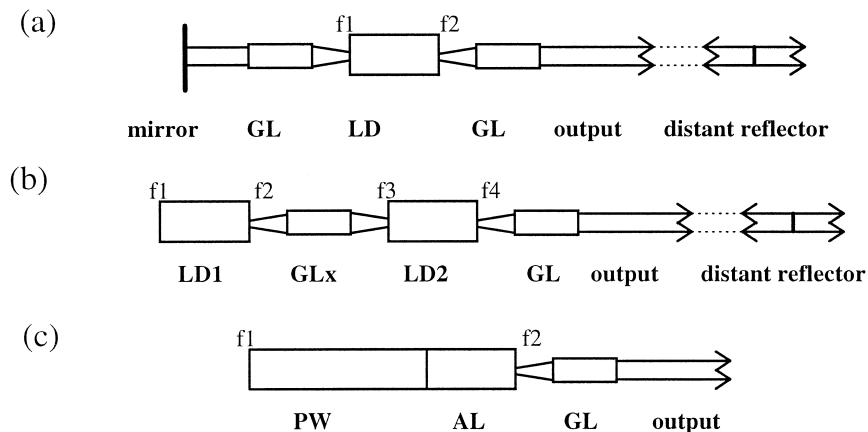

Fig. 5. Examples of diode configurations insensitive to additional feedback. (a) Regime V ECDL. Output is from facet 2 (no coating), and anti-reflection coated facet 1 receives feedback from high reflection coated mirror. (b) Master (LD1)/slave (LD2) pair. Facets 1 and 3 are HR coated, facet 2 is AR coated and facet 4 is AR or uncoated. LD1 is operated at much higher current than LD2. (c) Integrated device version of (a) with an active laser section (AL) with  $f_2$  with a low reflectance (LR) coating and a passive waveguide section (PW) terminated with a high reflectance (HR) coating for strong optical feedback. This device is called an optical feedback insensitive laser diode (OFILD). The output facet of the AL section has a low reflectance (LR) coating. GL is 0.23 pitch GRIN lens, GLx is a 0.29 pitch GRIN lens.

from the feedback. In this device the strong feedback from facet 1 acts to self lock the diode laser and, providing that the feedback can be made large enough in comparison with any other reflections entering the diode laser from facet 2 (which may lead to coherence collapsed behaviour), then the output will remain single mode. Fig. 5(b) shows a slightly different arrangement. A master diode laser 1 is used to inject a signal into the slave diode laser 2. Facets 1 and 3 are high reflection coated, and facets 2 and 4 are anti-reflection coated. In this configuration no isolation is required between the master and slave lasers as the strong feedback from facet 3 into diode laser 1 ensures that this diode laser operates as a stable single mode regime V LDWOF. If feedback from a distant reflector is sufficient to cause diode laser 2 to operate in the coherence collapsed state, then the injected signal from the LDWOF comprising diode laser 1 and facet 3 will act to lock the two laser diodes in frequency resulting in a stable single mode output. Although the coherence collapsed signal of diode laser 2 is being injected into diode laser 1, operating diode laser 1 at a much higher power (and due to the reflectivity coatings) ensures that the injected field is much stronger than the optical feedback field. The consequence of this large power difference is that there is no change to the output stability, as the experiments have shown. This is similar to a cleaved coupled cavity diode laser, which typically provides longitudinal mode selection due to the difference in length of the two diodes. Such diode lasers are still sensitive to unwanted feedback, although less so than a solitary diode laser [29]. The first of these designs is suitable for fabrication as an integrated device using an active laser section and a passive waveguide section with a total length of a few millimeters as depicted in Fig. 5(c).

#### 4.2. Injection locking of a frequency modulated ECDL

This study also examined the effect of injection locking a frequency modulated (FM) ECDL. The occurrence of modulation induced coherence collapse in an FM ECDL has been reported previously [19,20]. This form of coherence collapse significantly limits the attainable FM bandwidth from an FM ECDL compared to the several THz bandwidths

potentially available by comparison with other broad gain bandwidth FM lasers. In the first experiments the frequency modulation is achieved by directly modulating the diode laser injection current. The maximum modulation index,  $\beta$ , attainable, before the onset of coherence collapse, as a function of the detuning of the modulation frequency from the longitudinal mode spacing of the external cavity, is shown in Fig. 6. The modulation index is defined, in the usual way, as the ratio of the maximum frequency deviation to the modulation frequency and  $\beta$  is determined from the ratio of the intensity of the first FM sideband to the carrier. The largest pre-coherence collapse bandwidths occur for the largest detunings. If there was no transition to coherence collapse it would be expected that very large bandwidths would be found close to zero detuning, as this represents the greatest enhancement of the modulation sidebands by the external cavity modes [30].

The effect of injection locking on the FM characteristics is displayed in Fig. 7, which shows the modulation index,  $\beta$ , as a function of the modulation power. For a free running FM ECDL (close to zero detuning) the modulation index increases with modulation power until at a certain point coherence collapse is reached (curve (a)). If the detuning is increased (curve (c)) then at any given modulation power the modulation index is reduced, but the modulation power can be driven higher before transition to coherence collapse, thus a slightly larger bandwidth is found. Similarly, if the feedback from

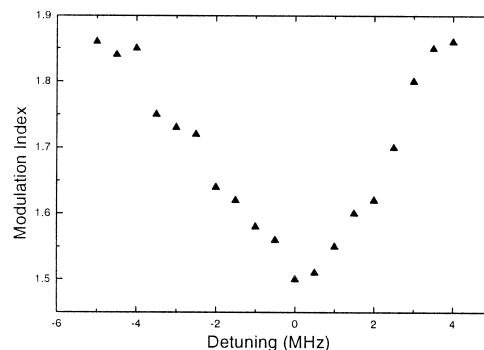

Fig. 6. Maximum modulation index  $\beta$  before transition to coherence collapse as a function of the detuning of the modulation frequency from the longitudinal mode spacing of external cavity. Data is for a directly modulated diode laser with 20% external optical feedback (defined as in Fig. 3).

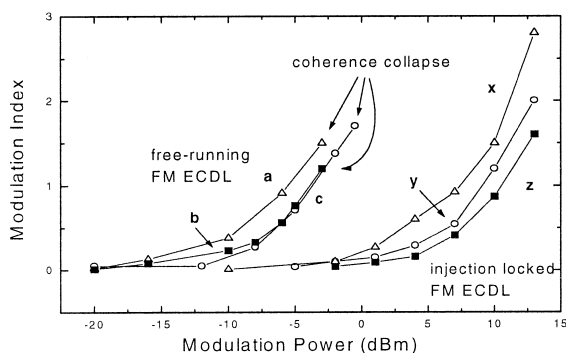

Fig. 7. Modulation index ( $\beta$ ) as a function of the modulation power. (a), (b), and (c) free running FM ECDL; (x), (y), (z) injection locked FM ECDL. (a) and (x) detuning = 1 MHz,  $R_{\text{ext}} = 0.3$ ; (b) and (z) detuning = 1 MHz,  $R_{\text{ext}} = 0.25$ ; and (c) and (y) detuning = 6 MHz,  $R_{\text{ext}} = 0.3$ . External cavity length for all cases is 317 mm, i.e. zero detuning is obtained for a modulation frequency of 473 MHz.

the external mirror is reduced (again at close to zero detuning) then at a given modulation power the modulation index is also reduced but the transition to coherence collapse occurs sooner, and thus lower bandwidths are obtained (curve (b)). For the injection locked FM ECDL the analogous curves (zero detuning (x), increased detuning (y) and decreased feedback (z)) show that the injected signal significantly reduces the modulation index at any modulation power but suppresses the transition to coherence collapse (as is also seen for the free running regime IV ECDL). Thus, larger FM bandwidths are achievable because the FM transition to coherence collapse is suppressed and higher useful modulation powers may be used. If the seed power is slightly less than that necessary to lock the two lasers, then a dynamically unstable state is reached, similar to that previously mentioned. If the seed beam power is very much less than the power of the slave laser then there is no observable effect on the frequency spectrum.

No transition to coherence collapse has been seen up to the maximum modulation power available with the current experimental apparatus (5 V peak-to-peak) which is close to the damage threshold of the diode. This corresponds to an increase in maximum modulation index by a factor of approximately two. However, it is expected that larger increases in obtainable FM bandwidths should be achieved with modified

experimental arrangements. In the present experimental set-up there is a limit to the amount of feedback provided from the external mirror due to the intra-cavity beam splitter. Injecting into the back facet of the diode would allow larger feedback into the diode, hence larger modulation index enhancement due to the external cavity modes.

The reduction in the modulation index with injection locking has previously been reported for solitary frequency modulated diode lasers subject to injected signals [25,26,31]. It was reported that this reduction is proportional to the injection power ratio, i.e. at high injected signal powers the output modulation is significantly suppressed, but it is not effected at low injection power ratios. The present work found similar results. However, the suppression of the modulation index was found to be significantly larger with an ECDL as opposed to a laser diode. This may be considered equivalent to a suppression of the FM noise, and hence leads to linewidth reduction [32–34], which is expected to be much greater for an injection locked ECDL compared to an injection locked laser diode by virtue of the optical feedback.

The disadvantage of providing larger bandwidths due to injection locking an FM ECDL is that the corresponding amplitude modulation is larger. The amplitude modulation that accompanies any frequency modulation is due to the large dependence of the carrier density on the refractive index which is found in semiconductor lasers. It manifests itself as an asymmetry in the sidebands of the frequency modulated signal. This is shown in Fig. 8 where Fig. 8(a) is the free running FM ECDL at a modulation index of 1.5, and Fig. 8(b) is the injection locked FM ECDL at a similar modulation index, which shows substantial asymmetry. Thus, the injected signal has a larger effect on the carrier density than the feedback field.

The above experiments have also been performed with an FM ECDL whose modulation is provided by an intra-cavity phase modulator. The bandwidths obtainable with the intra-cavity FM ECDL (with no injected signal) are greater than for the directly modulated FM ECDL, because of the increased modulation enhancement due to multiple passes in the system, and the accompanying amplitude modulation is much less, because there is less carrier heating within the diode. When such a system is injection

locked the suppression of the modulation index is much greater than for the directly modulated ECDL (by a factor of 100). While this modulation index suppression is assumed to be accompanied by a suppression of the transition to coherence collapse, because the index suppression is so large the modulator must be driven with much higher powers which risks damage to the modulation crystal. Thus, the bandwidths obtained in the injected-locked phase-modulated FM ECDL are much less than those obtained with the unlocked phase-modulated FM ECDL.

As for the injection locked LDWOF, integrated device designs are proposed (Fig. 9) to exploit self locking and intracavity phase modulation. Fig. 9(a) is similar to the OFILD shown in Fig. 5(c) except it has a separate modulator section which has the same layer structure as the laser section but which is reverse biased and modulated to achieve FM ECDL operation. The device shown in Fig. 9(b) additionally incorporates an active waveguide section which is biased to independently compensate for amplitude modulation as has been demonstrated in mode locked diode lasers [35]. Such devices have the potential to be the very broad bandwidth, compact, FM lasers

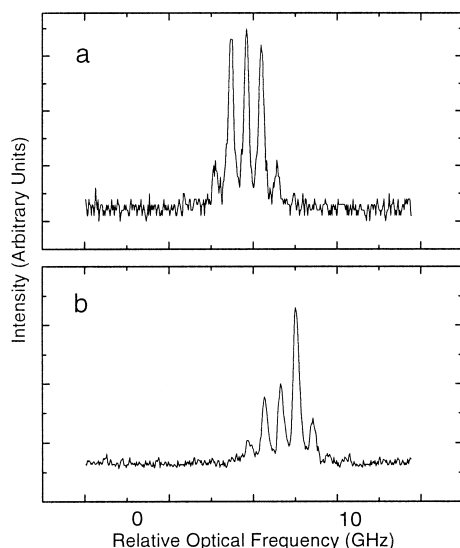

Fig. 8. Optical frequency spectra of frequency modulated ECDL: (a) free-running ECDL; and (b) injection locked ECDL. Modulation frequency is 470 MHz. Both scans show approximately 12 GHz.

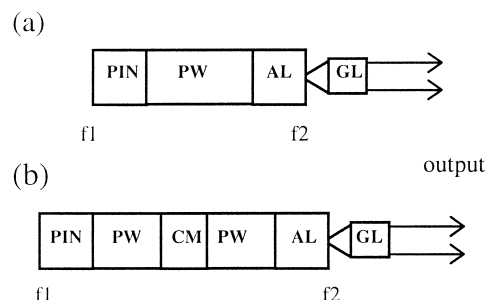

Fig. 9. Integrated device designs for FM laser diodes which are not susceptible to modulation induced coherence collapse. AL: active laser section, PIN: modulator section, PW: passive waveguide section, CAM: amplitude modulation compensation section, GL: 0.23 pitch GRIN lens, facets f1 have a high reflectance coating and facets f2 have a low reflectance coating.

suitable for application in frequency division multiplexing and optical metrology. Developments in suitable impurity induced disordered and quantum well intermixed semiconductor materials to fabricate these passive/active multi-section devices are emerging at this time [36].

### 5. Conclusion

Frequency modulated ECDL operation with injection locking has been examined. It has been shown that the injected signal acts to reduce the modulation index of the FM oscillation. However, it also suppresses the transition to coherence collapse which is a characteristic of such FM ECDLs. Due to this suppression larger bandwidths are obtainable with injection locking than without. There is increased AM associated with the FM output as evidenced by sideband asymmetry in the FM optical frequency spectrum. Integrated device designs have been proposed which have the potential to overcome these difficulties and to produce practically significant FM ECDLs.

The spectral properties of semiconductor diode lasers subject to both optical feedback and optical injection have been examined. It has been found that if the injected signal is of sufficient power to lock the slave laser frequency, it will suppress any transition to coherence collapse that may arise due to optical feedback into the diode laser. Systems which incorporate such suppression have been proposed as

possible diode laser sources that are insensitive to optical feedback and which do not require any optical isolation.

### Acknowledgements

This research was supported by an Australian Research Council Large Grant. J.S. Lawrence acknowledges the receipt of a Macquarie University Postgraduate Research Award.

### References

- [1] R. Lang, K. Kobayashi, *IEEE J. Quantum Electron.* 16 (1980) 347.
- [2] N. Schunk, K. Petermann, *IEEE J. Quantum Electron.* 24 (1988) 1242.
- [3] K. Petermann, *IEEE J. Sel. Top. Quantum Electron.* 1 (1995) 480.
- [4] R.W. Tkach, A.R. Chraplyvy, *IEEE J. Lightwave Technol.* 4 (1986) 1655.
- [5] Y. Liu, N. Kikuchi, J. Ohtsubo, *Phys. Rev. E* 51 (1995) R2697.
- [6] Y. Liu, J. Ohtsubo, *IEEE J. Quantum Electron.* 33 (1997) 1163.
- [7] N. Kikuchi, Y. Liu, J. Ohtsubo, *IEEE J. Quantum Electron.* 33 (1997) 56.
- [8] A.T. Ryan, G.P. Agrawal, G.R. Gray, E.C. Gage, *IEEE J. Quantum Electron.* 30 (1994) 668.
- [9] J. Wieland, C.R. Mirasso, D. Lenstra, *Opt. Lett.* 22 (1997) 469.
- [10] S. Kobayashi, T. Kimura, *IEEE J. Quantum Electron.* 17 (1981) 681.
- [11] R. Lang, *IEEE J. Quantum Electron.* 18 (1982) 976.
- [12] I. Petitbon, P. Gallion, G. Debarge, C. Chabran, *IEEE J. Quantum Electron.* 24 (1988) 148.
- [13] L. Li, *IEEE J. Quantum Electron.* 30 (1994) 1701.
- [14] F. Mogensen, H. Olesen, G. Jacobsen, *IEEE J. Quantum Electron.* 21 (1985) 784.
- [15] V. Annovazzi-Lodi, S. Donati, M. Manna, *IEEE J. Quantum Electron.* 30 (1994) 1537.
- [16] J. Dellunde, C.R. Mirasso, M.C. Torrent, J.M. Sancho, E. Hernandez-Garcia, *Opt. Quantum Electron.* 27 (1995) 755.
- [17] V. Vassiliev, V. Velichansky, P. Kersten, F. Riehle, *Electron. Lett.* 33 (1997) 1222.
- [18] P. Saboureau, J. Foing, P. Schanne, *IEEE J. Quantum Electron.* 33 (1997) 1582.
- [19] A.P. Willis, D.M. Kane, *Opt. Commun.* 107 (1994) 65.
- [20] A.P. Willis, D.M. Kane, *Opt. Commun.* 111 (1994) 577.
- [21] A.E. Siegman, *Lasers*, University Science Books, Mill Valley, CA, USA, 1986.
- [22] S.E. Harris, R. Targ, *Appl. Phys. Lett.* 5 (1964) 202.
- [23] S.E. Harris, O.P. McDuff, *IEEE J. Quantum Electron.* 1 (1965) 245.
- [24] S. Kobayashi, Y. Yamamoto, M. Ito, T. Kimura, *IEEE J. Quantum Electron.* 18 (1982) 582.
- [25] S. Kobayashi, in: Y. Yamamoto (Ed.), *Coherence, Amplification, and Quantum Effects in Semiconductor Lasers*, Wiley, 1991.
- [26] S. Kobayashi, T. Kimura, *IEEE J. Quantum Electron.* 18 (1982) 575.
- [27] D.M. Kane, A.P. Willis, *Appl. Opt.* 34 (1995) 4316.
- [28] J.S. Lawrence, D.M. Kane, *Opt. Commun.* 159 (1999) 316.
- [29] N.A. Olsson, N.K. Dutta, *Appl. Phys. Lett.* 44 (1998) 840.
- [30] A.J. Lucero, R.W. Tkach, R.M. Derosier, *Electron. Lett.* 24 (1988) 337.
- [31] S. Kobayashi, Y. Yamamoto, T. Kimura, *Electron. Lett.* 17 (1981) 849.
- [32] S. Saito, F. Mogensen, H. Olesen, *Electron. Lett.* 21 (1985) 1173.
- [33] F. Mogensen, H. Olesen, G. Jacobsen, *Electron. Lett.* 21 (1985) 696.
- [34] T.B. Simpson, J.M. Liu, A. Gavrielides, *IEEE Photon. Technol. Lett.* 7 (1995) 709.
- [35] R. Nagar, D. Abraham, G. Eisenstein, *Opt. Lett.* 17 (1992) 1119.
- [36] F. Camacho, E. Avrutin, A.C. Bryce, J.H. Marsh, *IEE Proc. Optoelectron.* 145 (1998) 43.